

BASKET STRAINER

Model FB7208 Ductile Iron

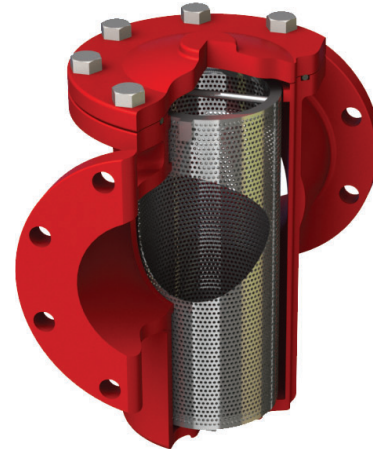

Available:
Flange x Flange

Description:

1. Flange dimensions conform to ANSI B16.1 Class 125
2. Fusion Bond Epoxy Coated Interior and Exterior, AWWA C550.
3. Working Pressure: 175 psi
4. Working Temperature: 14°F - 248°F
5. The surface area of the screen openings are minimum ratio of 6 to 1 of the cross-sectional area of the pipe waterway.
6. Sizes 3"~6" - Plug at the bottom of body
Sizes 8"~12" - Plug on the side of body

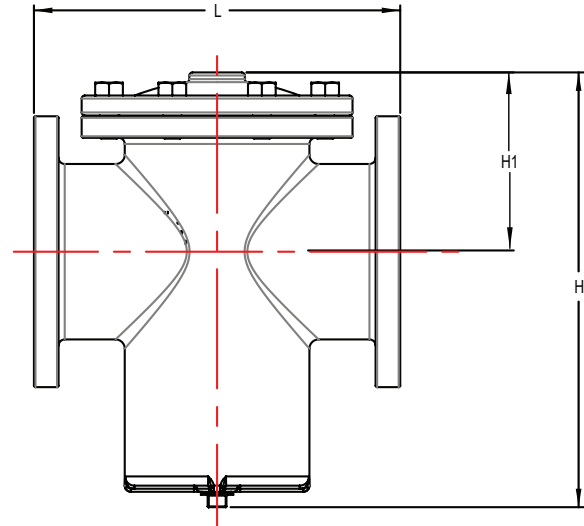

MATERIAL LIST

DESCRIPTION	MATERIAL	ASTM SPECIFICATION
Body	Ductile Iron	ASTM A536 65-45-12
Cover	Ductile Iron	ASTM A536 65-45-12
Screen	Stainless Steel	AISI 304
Gasket	Rubber	EPDM
Bolts	Carbon Steel	Grade 8.8
Nuts	Carbon Steel	Grade 8.8
Plug	Malleable Iron	-
Eye Bolt	Carbon Steel	Grade 4.8

Design, dimensions and materials are subject to change without notice.

DIMENSIONAL DATA

Nominal Size	Part No.	L	H	H1	Plug
3"	FB7208-130	9.84	12.20	5.91	3/4
4"	FB7208-140	11.50	16.14	7.68	1
5"	FB7208-150	13.39	17.72	8.86	1
6"	FB7208-160	14.88	21.46	10.83	1
8"	FB7208-180	18.74	26.97	12.20	1.5
10"	FB7208-200	22.00	30.12	14.17	1.5
12"	FB7208-220	26.77	37.40	18.11	2

Dimensions in inches



WARNING: This product can expose you to chemicals including lead, which is known to the State of California to cause cancer and birth defects or other reproductive harm. For more information go to www.P65Warnings.ca.gov.



United Water Products
5355 Ramona Blvd., Jacksonville, FL 32205
TEL. 877-766-4459 FAX: 877-766-4458
Website: www.unitedwaterproducts.com



Pressure Loss Chart

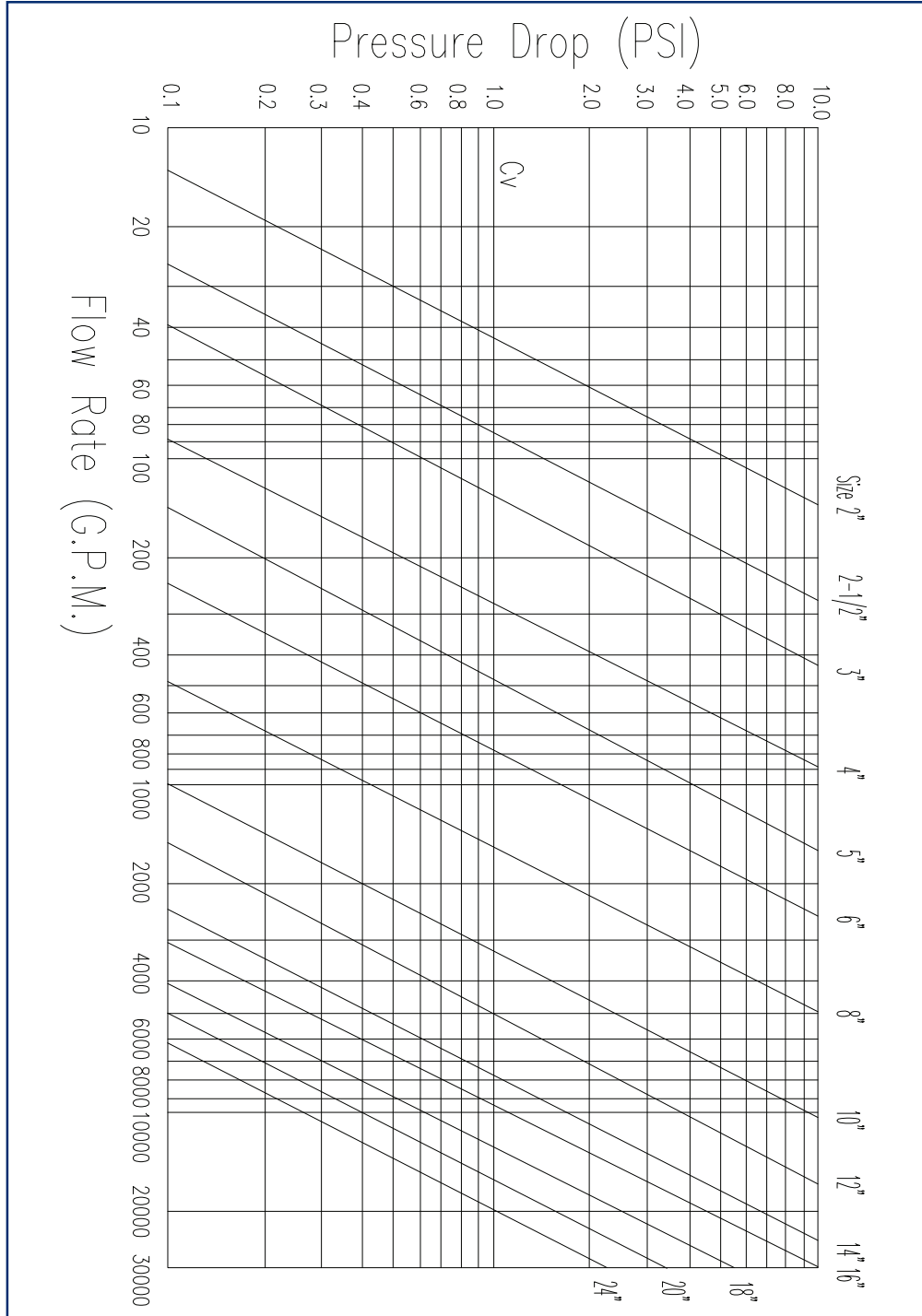

The above chart is based on clean water and ambient temperature.